

Low power consumption, Low ESR Cap. Compatible ME6206 Series

General Description

ME6206 series are highly precise, low power consumption, high voltage, positive voltage regulators manufactured using CMOS and laser trimming technologies. The series provides large currents with a significantly small dropout voltage. The series is compatible with low ESR ceramic capacitors. The current limiter's foldback circuit also operates as a short protect for the output current limiter and the output pin.

Features

- Highly Accurate: $\pm 2\%$
- Output voltage range: 1.5V~5.0V (selectable in 0.1V steps)
- Low power consumption: 8uA(TYP.)
- Large output current: 300mA ($V_{IN}=4.3V, V_{OUT}=3.3V$)
- Input voltage: up to 6 V
- Excellent Input Stability
- Be available to regulator and reference voltage
- Packages: SOT23-3, SOT89-3, SOT23, TO-92

Selection Guide

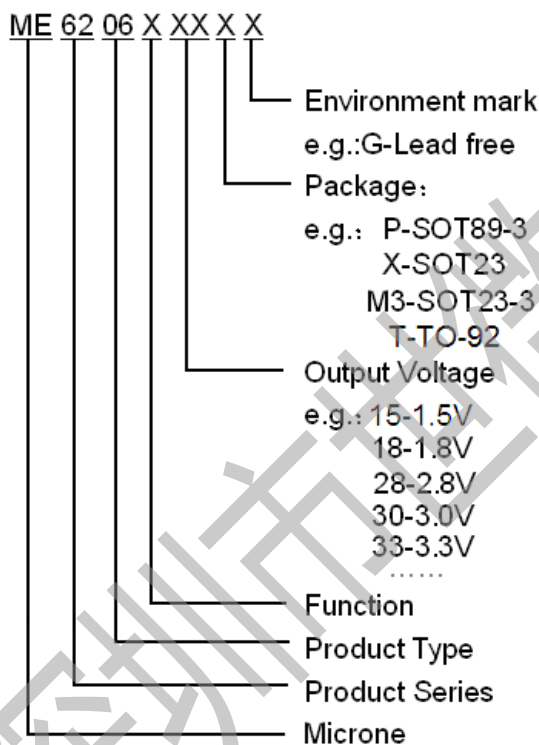

Typical Application

- Battery powered equipment
- Communication tools
- Mobile phones
- Portable games
- Portable AV systems
- Cameras, Video systems
- Reference voltage sources

Typical Application Circuit

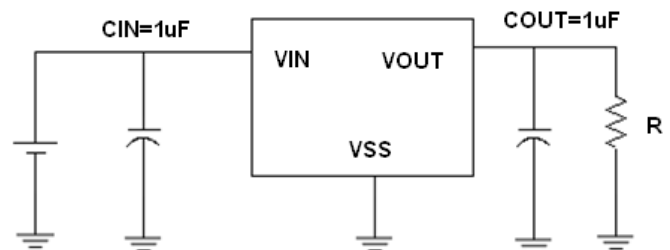

Product	Supply Current
ME6206A	8 uA
ME6206K	180 uA

Pin Configuration

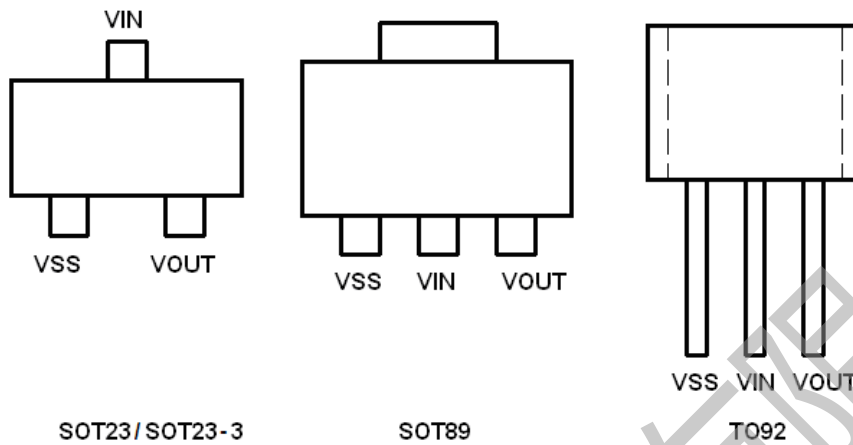

Pin Assignment

ME6206Axx/ ME6206Kxx

Pin					Name	Function
M3	P	P1	X	T		
SOT23-3	SOT89-3	SOT89-3	SOT23	TO-92		
1	1	2	1	1	Vss	Ground
2	3	1	2	3	Vout	Output
3	2	3	3	2	Vin	input

The difference of mark on the chip between P and P1 is : P: 6206A , P1: 6206A1

Absolute Maximum Ratings

Parameter	Symbol	Description	Units
Input Voltage	V_{IN}	6.5	V
Output Current	I_{out}	500	mA
Output Voltage	V_{out}	$V_{ss}-0.3 \sim V_{out}+0.3$	V
Power Dissipation	SOT23-3	P_d	300 mW
	SOT89-3	P_d	500 mW
	SOT23	P_d	300 mW
	TO-92	P_d	500 mW
Operating Ambient Temperature	T_{Opr}	-25 ~ +85	°C
Storage Temperature	T_{stg}	-40 ~ +125	°C

Block Diagram

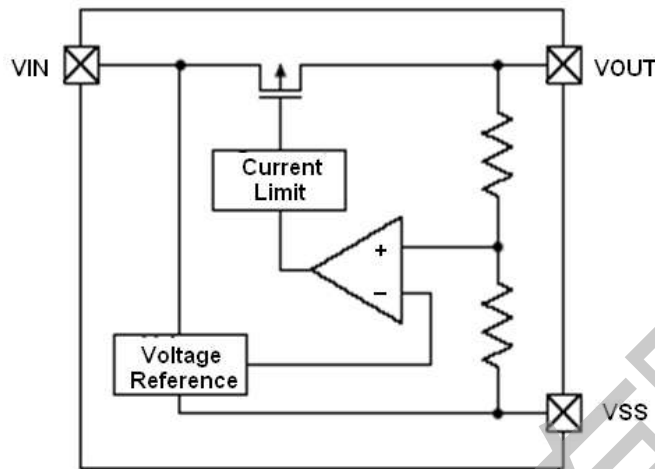

ME6206A15

(VIN=Vout+1V,Cin=Cout=1uF,Ta=25°C Unless otherwise stated)

PARAMETER	SYMBOL	CONDITION	MIX	TYP	MAX	UNIT
Output Voltage	V _{OUT(E)} (Note 2)	I _{OUT} =10mA, V _{IN} =Vout+1V	X 0.98	V _{OUT(T)} (Note 1)	X 1.02	V
Input Voltage	V _{IN}				6	V
Maximum Output Current	I _{OUT (max)}	V _{IN} =Vout+1V		100	120	mA
Load Regulation	ΔV _{OUT}	V _{IN} =Vout+1V, 1mA ≤ I _{OUT} ≤ 80mA	-5	10	20	mV
Dropout Voltage (Note 3)	V _{dif1}	I _{OUT} =20mA		140	160	mV
	V _{dif2}	I _{OUT} =50mA		300	330	mV
Supply Current	I _{SS}	V _{IN} =Vout+1V	1	7	15	μA
Line Regulations	$\frac{\Delta V_{OUT}}{\Delta V_{IN} \cdot V_{OUT}}$	I _{OUT} =10mA Vout+1V ≤ V _{IN} ≤ 5V		0.1	0.3	%/V
Power Supply Ripple Rejection Ratio	PSRR	Vin= [Vout+1]V +1Vp-pAC I _{OUT} =10mA,f=1kHz		45		dB
Short Circuit Current	I _{short}	Vin=Vout(T)+1.5V Vout=Vss		20	50	mA
Over Current Protection	I _{limit}			300	350	mA

ME6206A18

(VIN=Vout+1V,Cin=Cout=1uF,Ta=25°C Unless otherwise stated)

PARAMETER	SYMBOL	CONDITION	MIX	TYP	MAX	UNIT
Output Voltage	V _{OUT} (E) (Note 2)	I _{OUT} =10mA, V _{IN} =Vout+1V	X 0.98	V _{OUT} (T) (Note 1)	X 1.02	V
Input Voltage	V _{IN}				6	V
Maximum Output Current	I _{OUT} (max)	V _{IN} =Vout+1V		120	150	mA
Load Regulation	ΔV _{OUT}	V _{IN} =Vout+1V, 1mA≤I _{OUT} ≤80mA	-5	12	27	mV
Dropout Voltage (Note 3)	V _{dif1}	I _{OUT} =20mA		140	160	mV
	V _{dif2}	I _{OUT} =50mA		300	330	mV
Supply Current	I _{SS}	V _{IN} =Vout+1V	1	7	15	μA
Line Regulations	$\frac{\Delta V_{OUT}}{\Delta V_{IN} \cdot V_{OUT}}$	I _{OUT} =10mA Vout+1V ≤V _{IN} ≤5V		0.1	0.3	%/V
Power Supply Ripple Rejection Ratio	PSRR	Vin= [Vout+1]V +1Vp-pAC I _{OUT} =10mA,f=1kHz		45		dB
Short Circuit Current	I _{short}	Vin=Vout(T)+1.5V Vout=Vss		25	50	mA
Over Current Protection	I _{limit}			400	450	mA

ME6206A28

(VIN=Vout+1V,Cin=Cout=1uF,Ta=25°C Unless otherwise stated)

PARAMETER	SYMBOL	CONDITION	MIX	TYP	MAX	UNIT
Output Voltage	V _{OUT} (E) (Note 2)	I _{OUT} =10mA, V _{IN} =Vout+1V	X 0.98	V _{OUT} (T) (Note 1)	X 1.02	V
Input Voltage	V _{IN}				6	V
Maximum Output Current	I _{OUT} (max)	V _{IN} =Vout+1V		300	350	mA
Load Regulation	ΔV _{OUT}	V _{IN} =Vout+1V 1mA≤I _{OUT} ≤100mA	-5	14	28	mV
Dropout Voltage (Note 3)	V _{dif1}	I _{OUT} =80mA		130	150	mV
	V _{dif2}	I _{OUT} =200mA		320	340	mV
Supply Current	I _{SS}	V _{IN} =Vout+1V		8	15	μA
Line Regulations	$\frac{\Delta V_{OUT}}{\Delta V_{IN} \cdot V_{OUT}}$	I _{OUT} =40mA Vout+1V ≤V _{IN} ≤6V		0.03	0.3	%/V
Power Supply Ripple Rejection Ratio	PSRR	Vin= [Vout+1]V +1Vp-pAC I _{OUT} =10mA,f=1kHz		50		dB
Short Circuit Current	I _{short}	Vin=Vout(T)+1.5V Vout=Vss		30	60	mA
Over Current Protection	I _{limit}			500	550	mA

ME6206A30

(VIN=Vout+1V,Cin=Cout=1uF,Ta=25°C Unless otherwise stated)

PARAMETER	SYMBOL	CONDITION	MIX	TYP	MAX	UNIT
Output Voltage	V _{OUT(E)} (Note 2)	I _{OUT} =10mA, V _{IN} =Vout+1V	X 0.98	V _{OUT(T)} (Note 1)	X 1.02	V
Input Voltage	V _{IN}				6	V
Maximum Output Current	I _{OUT} (max)	V _{IN} =Vout+1V		300	350	mA
Load Regulation	ΔV _{OUT}	V _{IN} =Vout+1V 1mA≤I _{OUT} ≤100mA	-5	14	28	mV
Dropout Voltage (Note 3)	V _{dif1}	I _{OUT} =80mA		140	160	mV
	V _{dif2}	I _{OUT} =200mA		330	350	mV
Supply Current	I _{SS}	V _{IN} =Vout+1V	1	8	15	μA
Line Regulations	$\frac{\Delta V_{OUT}}{\Delta V_{IN} \cdot V_{OUT}}$	I _{OUT} =40mA Vout+1V ≤V _{IN} ≤6V		0.03	0.3	%/V
Power Supply Ripple Rejection Ratio	PSRR	Vin= [Vout+1]V +1Vp-pAC I _{OUT} =10mA,f=1kHz		50		dB
Short Circuit Current	I _{short}	Vin=Vout(T)+1.5V Vout=Vss		30	60	mA
Over Current Protection	I _{limit}			500	550	mA

ME6206A33

(VIN=Vout+1V,Cin=Cout=1uF,Ta=25°C Unless otherwise stated)

PARAMETER	SYMBOL	CONDITION	MIX	TYP	MAX	UNIT
Output Voltage	V _{OUT(E)} (Note 2)	I _{OUT} =10mA, V _{IN} =Vout+1V	X 0.98	V _{OUT(T)} (Note 1)	X 1.02	V
Input Voltage	V _{IN}				6	V
Maximum Output Current	I _{OUT} (max)	V _{IN} =Vout+1V		300	350	mA
Load Regulation	ΔV _{OUT}	V _{IN} =Vout+1V 1mA≤I _{OUT} ≤100mA	-5	14	28	mV
Dropout Voltage (Note 3)	V _{dif1}	I _{OUT} =80mA		130	150	mV
	V _{dif2}	I _{OUT} =200mA		320	340	mV
Supply Current	I _{SS}	V _{IN} =Vout+1V		9	15	μA
Line Regulations	$\frac{\Delta V_{OUT}}{\Delta V_{IN} \cdot V_{OUT}}$	I _{OUT} =40mA Vout+1V ≤V _{IN} ≤6V		0.03	0.3	%/V
Power Supply Ripple Rejection Ratio	PSRR	Vin= [Vout+1]V +1Vp-pAC I _{OUT} =10mA,f=1kHz		50		dB
Short Circuit Current	I _{short}	Vin=Vout(T)+1.5V Vout=Vss		30	60	mA
Over Current Protection	I _{limit}			500	550	mA

ME6206K33

(VIN=Vout+1V,Cin=Cout=1uF,Ta=25°C Unless otherwise stated)

PARAMETER	SYMBOL	CONDITION	MIX	TYP	MAX	UNIT
Output Voltage	$V_{OUT}(E)$ (Note 2)	$I_{OUT}=10mA,$ $V_{IN}=V_{out}+1V$	X 0.98	$V_{OUT}(T)$ (Note 1)	X 1.02	V
Input Voltage	V_{IN}				6	V
Maximum Output Current	$I_{OUT} (max)$	$V_{IN}=V_{out}+1V$		300	350	mA
Load Regulation	ΔV_{OUT}	$V_{IN}=V_{out}+1V$ $1mA \leq I_{OUT} \leq 100mA$	-5	14	28	mV
Dropout Voltage (Note 3)	V_{dif1}	$I_{OUT} =80mA$		130	150	mV
	V_{dif2}	$I_{OUT} =200mA$		320	340	mV
Supply Current	I_{SS}	$V_{IN}=V_{out}+1V$	100	180	230	μA
Line Regulations	$\frac{\Delta V_{OUT}}{\Delta V_{IN} \cdot V_{OUT}}$	$I_{OUT} =40mA$ $V_{out}+1V \leq V_{IN} \leq 6V$		0.03	0.2	%/V
Power Supply Ripple Rejection Ratio	PSRR	$V_{in} = [V_{out}+1]V$ $+1V_{p-p}AC$ $I_{OUT} =10mA, f=1kHz$		50		dB
Short Circuit Current	I_{short}	$V_{in}=V_{out}(T)+1.5V$ $V_{out}=V_{ss}$		30	60	mA
Over Current Protection	I_{limit}			500	550	mA

Note :

- $V_{OUT}(T)$: Specified Output Voltage
- $V_{OUT}(E)$: Effective Output Voltage (i.e. The output voltage when " $V_{OUT}(T)+1.0V$ " is provided at the Vin pin while maintaining a certain Iout value.)
- V_{dif} : $V_{IN1} - V_{OUT}(E)'$
 V_{IN1} : The input voltage when $V_{OUT}(E)'$ appears as input voltage is gradually decreased.
 $V_{OUT}(E)'$: A voltage equal to 98% of the output voltage whenever an amply stabilized Iout { $V_{OUT}(T)+1.0V$ } is input.

Type Characteristics

(1) Output Current VS. Output Voltage ($V_{IN}=V_{out}+1$, $T_a = 25^\circ\text{C}$)

ME6206A18PG

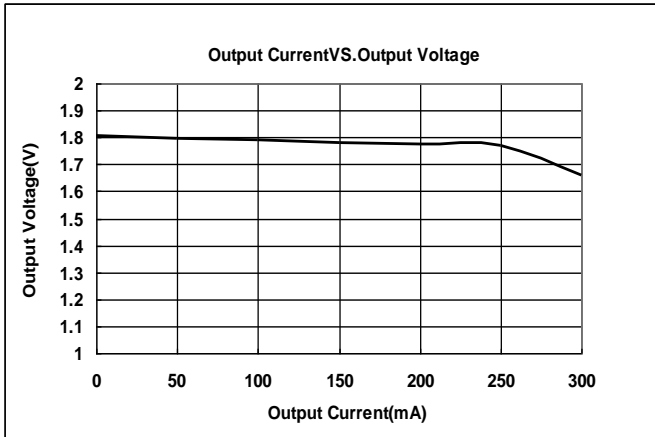

ME6206A28PG

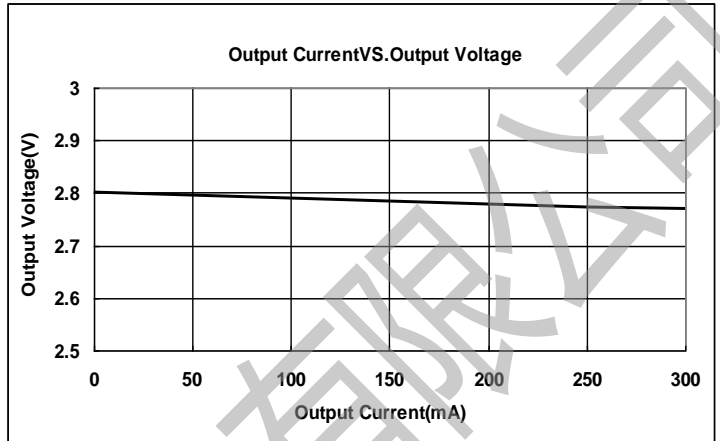

ME6206A30PG

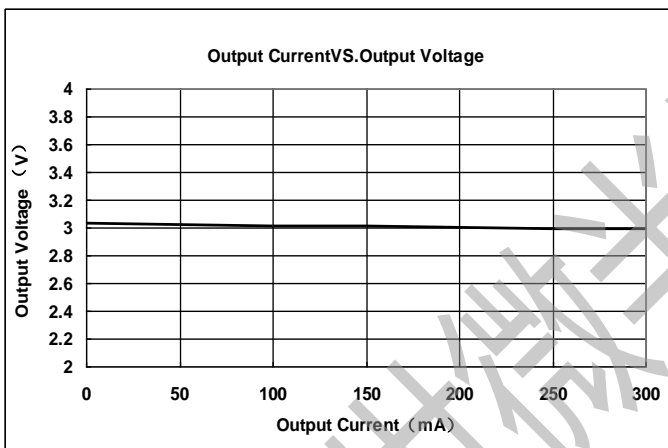

ME6206A33PG

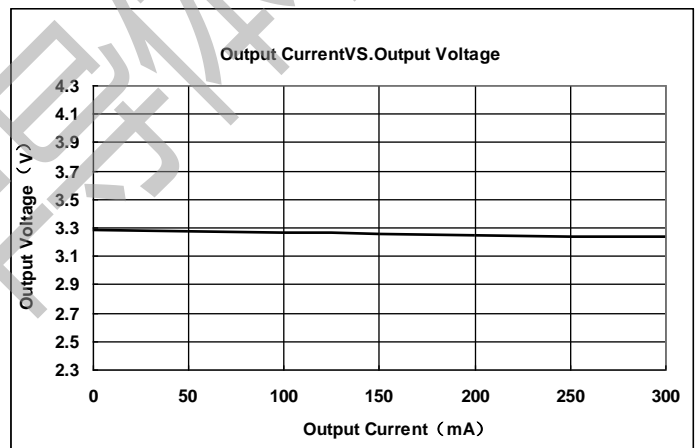

(2) Input Voltage VS. Output Voltage ($T_a = 25^\circ\text{C}$)

ME6206A18PG

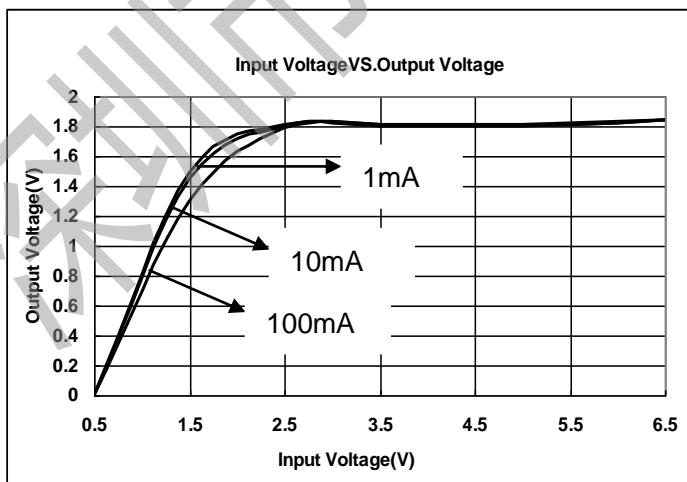

ME6206A28PG

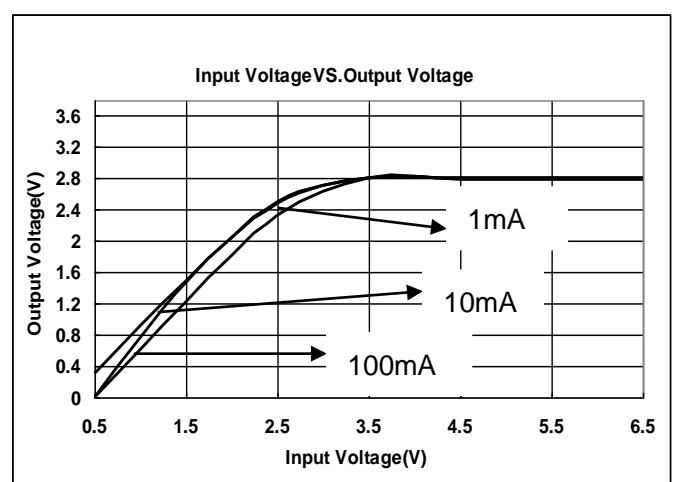

ME6206A30PG

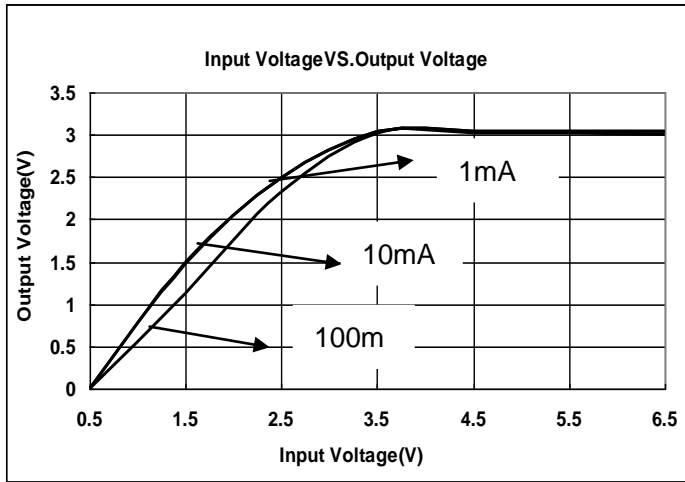

ME6206A33PG

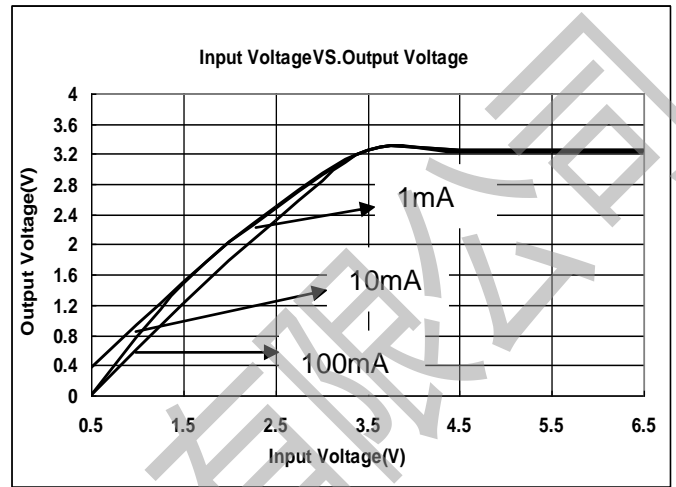

(3) Output Current VS. Dropout Voltage ($V_{IN}=V_{out}+1V, T_a = 25\text{ }^\circ\text{C}$)

ME6206A18PG

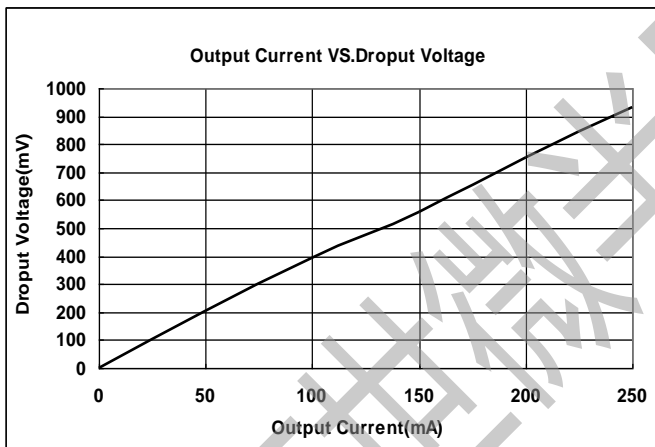

ME6206A28PG

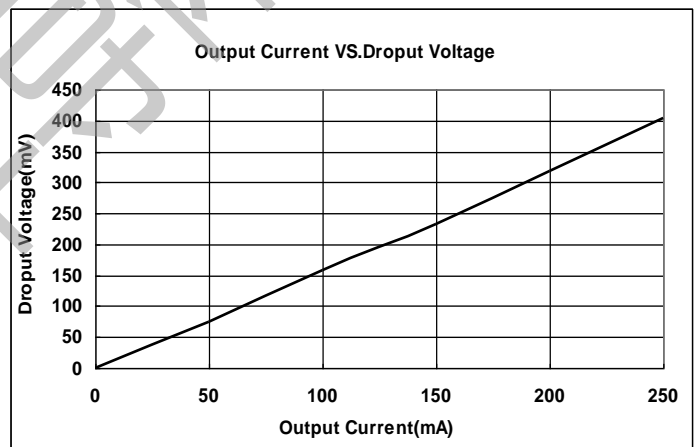

ME6206A30PG

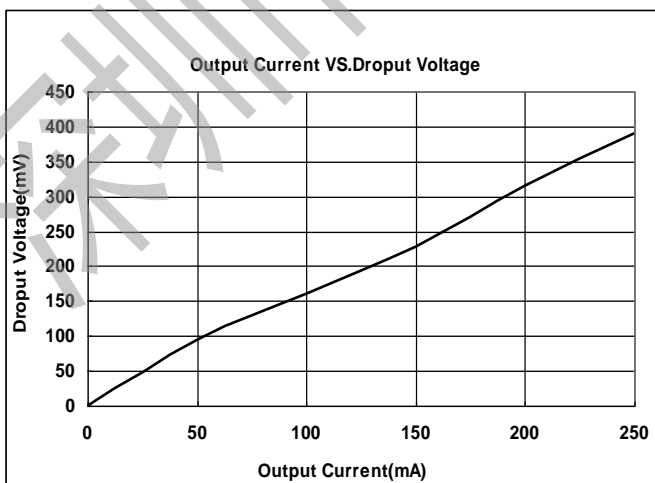

ME6206A33PG

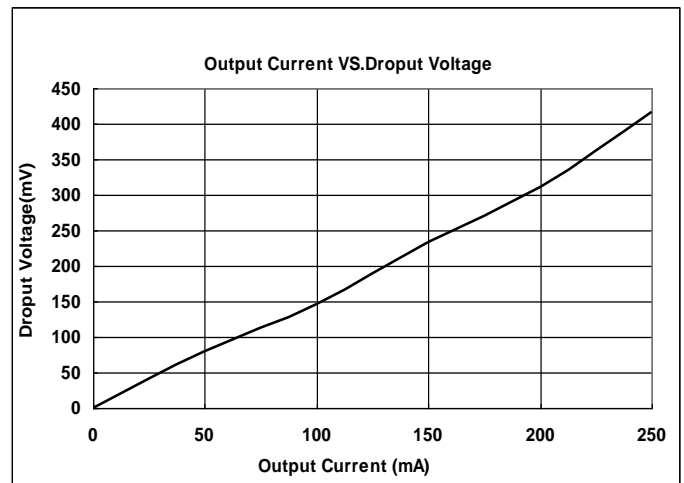

(4) Input Voltage VS. Supply Current ($T_a = 25^\circ\text{C}$)

ME6206A18PG

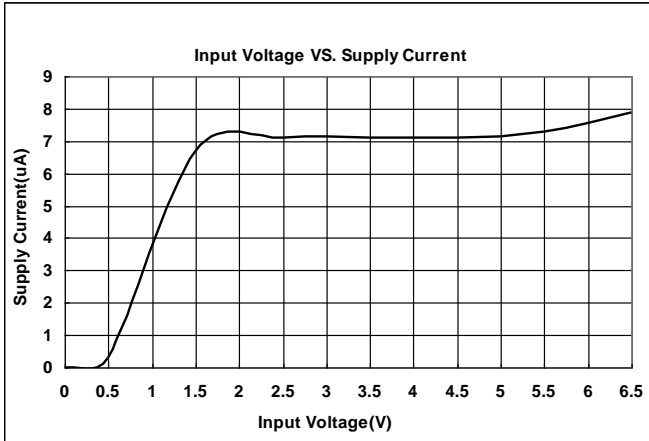

ME6206A28PG

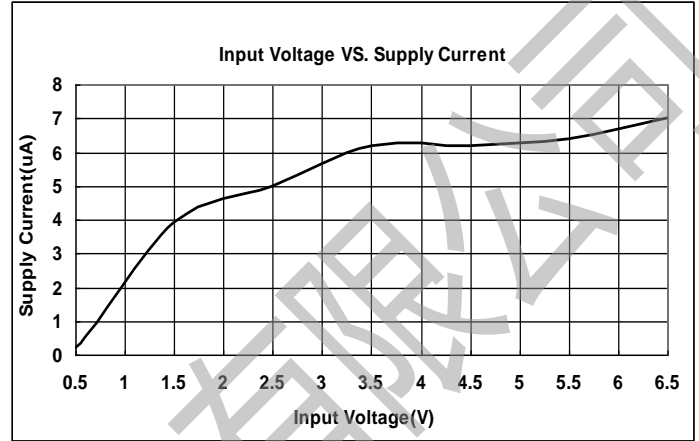

ME6206A30PG

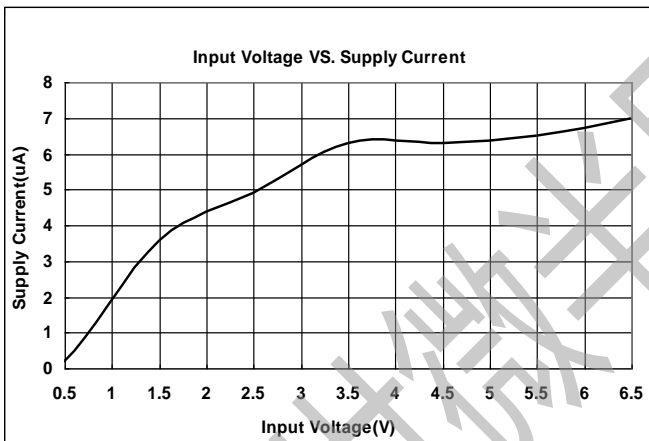

ME6206A33PG

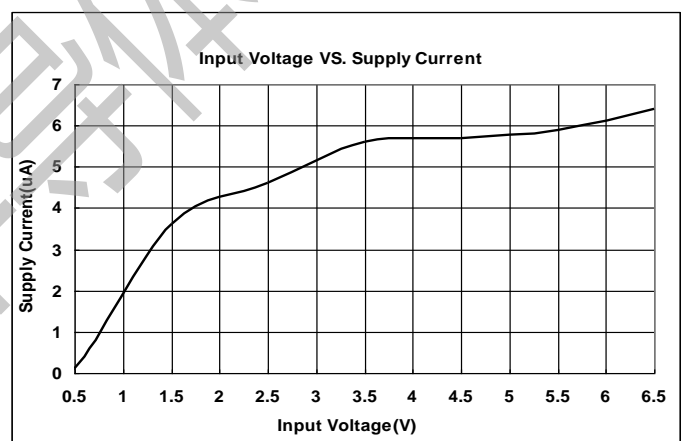

Packaging Information

- SOT89-3

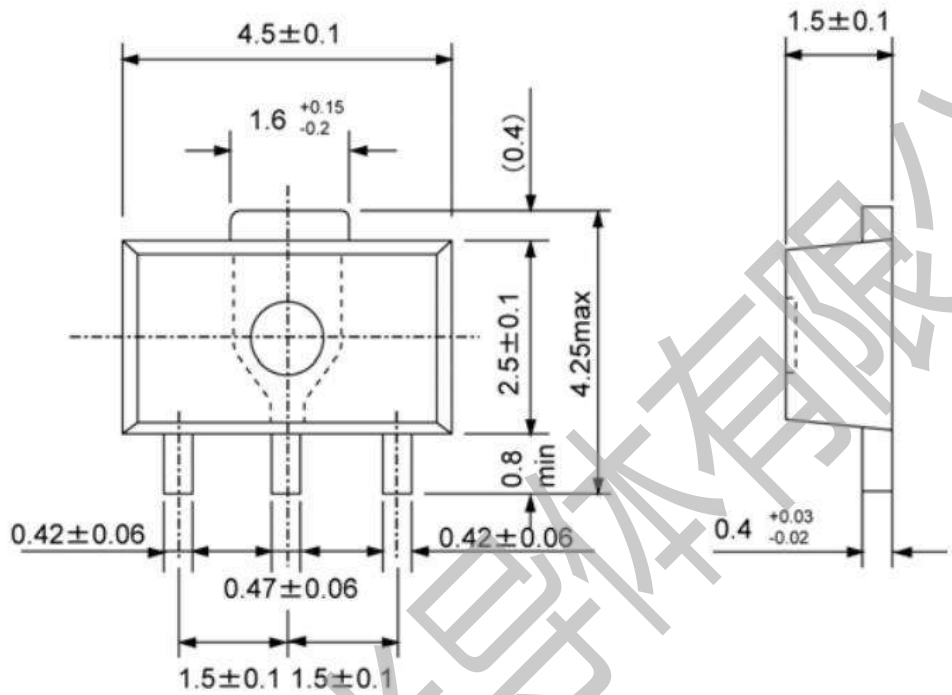

- SOT23-3

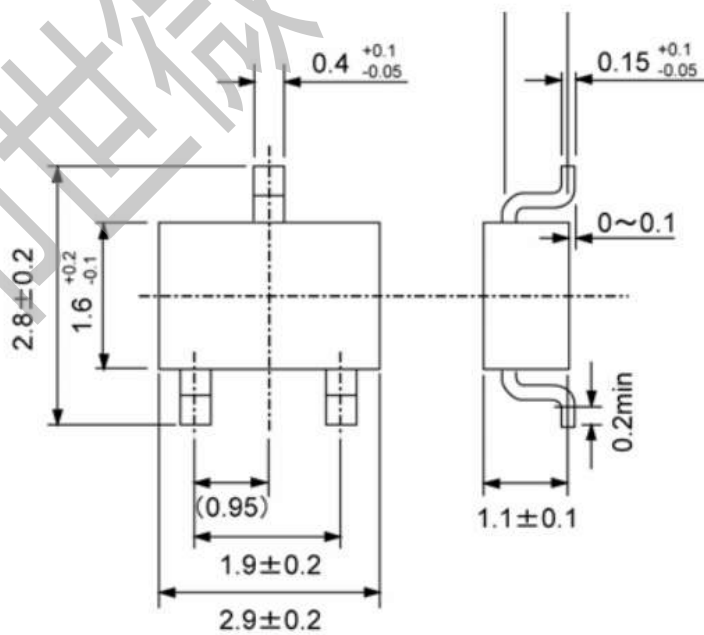

● SOT23

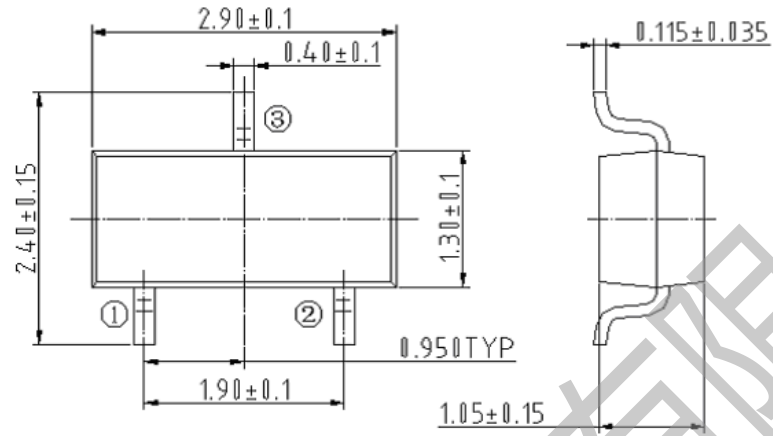

● TO-92

